

Luminaria a prueba de explosión LED

JET™ GHRS luminaria para áreas clasificadas es segura, confiable y resistente con el diseño exclusivo que maximiza la disipación de calor, ofrece un excelente rendimiento y eficiencia energética.

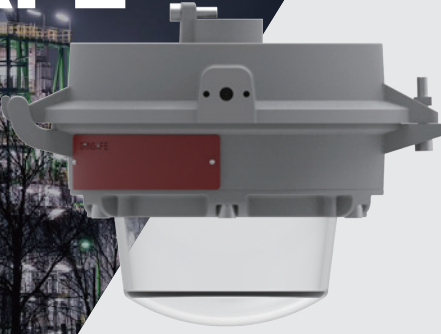

Certificaciones

Estándar NEC/CEC

- Clase I División 2, Grupo A, B, C, D
- Clase II División 1, Grupo E, F, G
- Clase II División 2, Grupo F, G
- Clase III
- Clase I, Zona 2, Grupo IIC
- Zona 21
- Zona 22

- UL 1598 Lugares Húmedos
- UL 1598A Marinas (Agua salina)
- CSA C22.2 No.137-M1981
- CSA C22.2 NO. 250.0

Garantía

- 5-años Garantía Limitada del Sistema
- Mantenimiento de Lúmenes: 150,000hrs@L70

Dimensiones

Dimensiones en milímetros (mm)

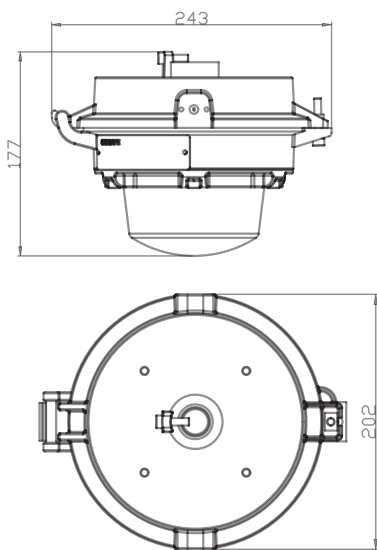

Ficha Técnica

Eléctrico

Potencia Nominal	10W / 20W / 30W
Voltaje de Entrada	AC100-277 V
Frecuencia de Entrada	50/60Hz
Factor de Potencia	> 0.95
Eficacia del Driver	≥ 90%
Salida de Ondulación & Ruido DC	< 200mVP-P

Óptica/Eficiencia

Salida de Lúmenes	1550lm / 3100lm / 4650lm
Eficacia Luminosa (Lúmenes Por Vatio)	155Lm/W
Ángulo de Haz	T1 / T3 / T5
Temperatura de Color Correlacionada	2700K 3000K 4000K 5000K
CRI	Ra>70

Ambiental

Temperatura ambiente	-40°C~+65°C
Humedad ambiental	10%~90% RH
Presión atmosférica	86~106KPa

Componentes/Montaje

Material de Lentes	Vidrio de lente
Opciones de Montaje	Colgante / A cielo / A pared / A poste / U-Soporte
Grado A Prueba de Corrosión	WF2
Especificación Glándula	3/4" NPT, 1" NPT, 1-1/4" NPT, 1-1/2"
Peso Neto	2.6kg

Distribución del Haz

Tipo V

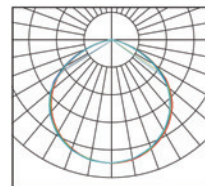

Configuración Para Armado De Código

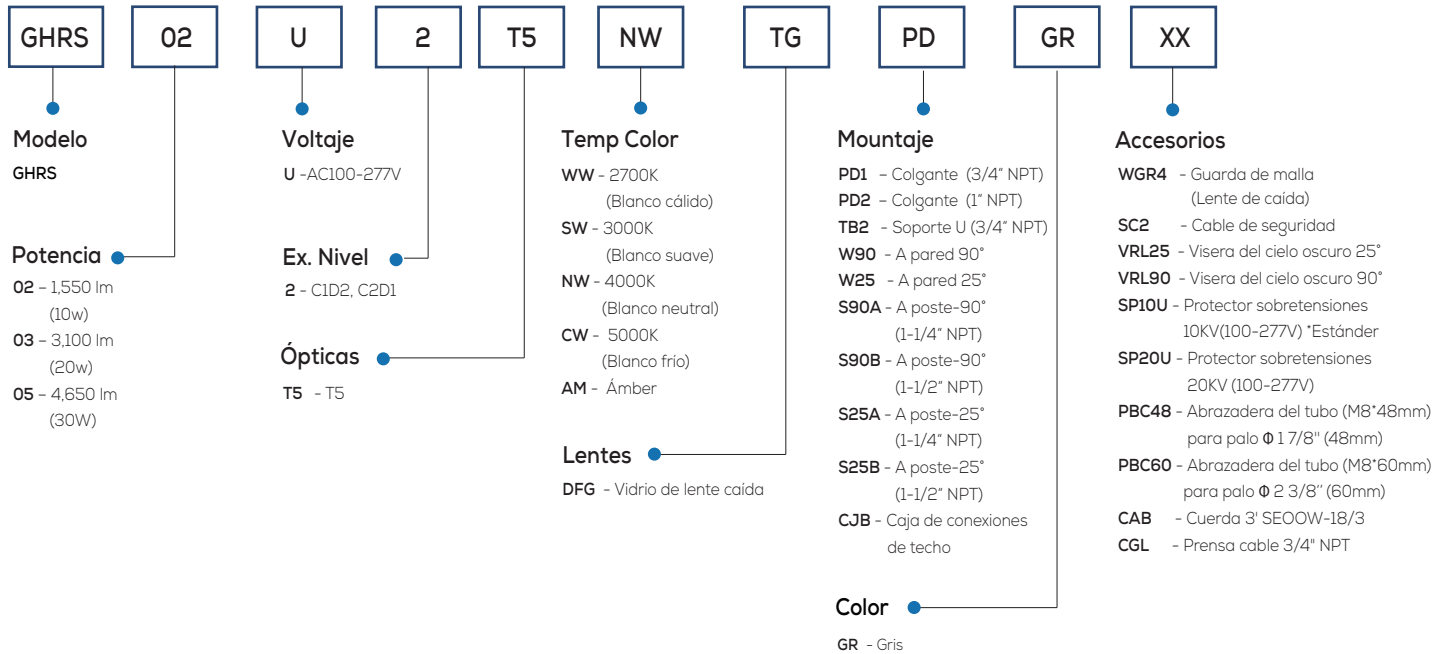



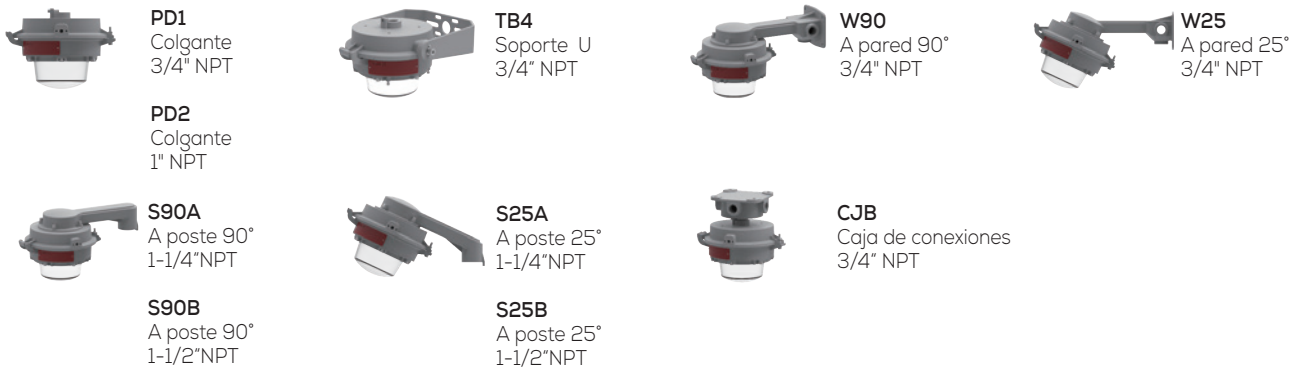













Opciones de Montaje



Accesorios



FAMILIA DE PRODUCTOS - LUMINARIAS PARA AREAS PELIGROSAS Y MEDIOAMBIENTES EXTREMOS

PRODUCTOS	CLASIFICACION	FLUJO LUMINOSO	PROTECCIÓN	PÁGINA
Scout GHSL™ 	 Clase I Div. 1 Clase I Div. 2 Clase II Div. 1	12,800lm~32,000lm 80W~200W	  	5
Flint GHSM™ 	 Clase I Div. 1 Clase I Div. 2 Clase II Div. 1	3,200lm~9,600lm 20W~60W	  	7
Cannon GHRL™ 	 Clase I Div. 2 Clase II Div. 1	13,600lm~34,000lm 80W~200W	  	9
Lance GHRM™ 	 Clase I Div. 2 Clase II Div. 1	6,500lm~10,200lm 40W~60W	  	11
Jet GHRS™ 	 Clase I Div. 2 Clase II Div. 1	1,550lm~4,600lm 10W~30W	  	13
Arrow GHLV™ 	 Clase I Div. 2 Clase II Div. 1	5,100lm~13,600lm 30W~80W	  	15
Firefly GHW™ 	 Clase I Div. 2 Clase II Div. 1	1,700lm~5,100lm 10W~80W	  	17
Barrel GELT™ 	  Zona 1, 2 Zona 21, 22	3,000lm~9,000lm 20W~60W	  	19
Storm GSM™ 		16,000lm~64,000lm 100W~400W	  	21
Blaze GSH™ 	 	16,000lm~72,000lm 100W~450W	  	23