



Alumbrado Público SL207

Eficiente, confiable y duradero

Especificaciones

70    
CRI 220-240V 50/60HZ 50,000 h No dimerizable

Nombre comercial	PILA SL207 LED70/ NW 50W DMO PSU	PILA SL207 LED98/ NW 70W DMO PSU	PILA SL207 LED140/ NW 100W DMO PSU	PILA SL207 LED210/ NW 150W DMO PSU	PILA SL207 LED280/ NW 200W DMO PSU
12NC	911401872387	911401872487	911401872087	911401872187	911401872287
Potencia (W)	50	70	100	150	200
Flujo luminoso (lm)	7.000	9.800	14.000	21.000	28.000
Eficiencia (lm/W)	140	140	140	140	140
Temperatura color (K)	4.000	4.000	4.000	4.000	4.000
IP	IP65	IP65	IP65	IP65	IP65
IK	IK08	IK08	IK08	IK08	IK08
Clase de seguridad	Clase I	Clase I	Clase I	Clase I	Clase I
Factor de potencia	> 0.9	> 0.9	> 0.9	> 0.9	> 0.9
Conexión	Cable	Cable	Cable	Cable	Cable

Incluye cable anti sifón.

Beneficios:

- ▶ Gran eficiencia y ahorro de energía
- ▶ Protección contra descargas atmosféricas 10kV incluida
- ▶ Fácil y rápido de instalar sin necesidad de apertura en poste (postop) o pescante
- ▶ Angulo ajustable (tilt) +/-15°
- ▶ Larga vida útil: 50.000 h L70B50
- ▶ 3 años de garantía

Aplicaciones:

- ▶ Avenidas
- ▶ Calles
- ▶ Estacionamientos
- ▶ Perímetros de seguridad
- ▶ Sendas peatonales
- ▶ Bicisendas

PILA Streetlighting

SL207

Mounting instruction



Max. 50 °C Min. -40 °C		IEC 60598	IP66	IK08	$t_a 35^{\circ}\text{C}$		RoHS	220-240V 50/60Hz		Class I
---------------------------	--	---------------------	-------------	-------------	--------------------------	--	-------------	---------------------	--	----------------

Type	Power/W(max.)	Wind force(m ²)	Weight(Kg)
SL207 LED67/NW 50W DM0 PSU	50W	0.059	1.72
SL207 LED98/NW 70W DM0 PSU	70W	0.065	1.66
SL207 LED140/NW 100W DM0 PSU	100W	0.086	1.98
SL207 LED210/NW 150W DM0 PSU	150W	0.104	2.25
SL207 LED280/NW 200W DM0 PSU	200W	0.13	2.59

Product Size

Unit: mm

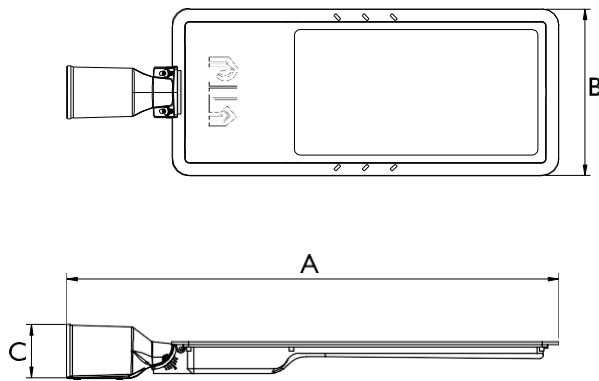

Type	A	B	C
50W	505	135	76
70W	545	168	76
100W	618	185	76
150W	645	210	76
200W	700	237	76

* Luminaire with 0.4M cable(s)



Notice: Correct connection for polarities.

Recommended to use waterproof box IP66, the dimension value must be below the pole arm inner diameter value, to ensure it go through the pole arm. Waterproof box is not provided by Signify.



Install the luminaire according to the national regulation and make sure the luminaire installed safely and firmly the lamp pole. Make sure the luminaire installed safely and securely to the lamp pole. Installation with over recommended torque may cause the slippery or crack of spigot.