

250A Plug-in Type Elbow Connector WEZT 24/250

Design

1. Probe

Tinned copper probe to thread into the conductor lug with the supplied tool

2. External Screen

Moulded conductive EPDM rubber to ensure the connector touchable

3. Insulation

Moulded insulated EPDM rubber to ensure excellent electrical properties

4. Pulling eye

Provide a detent to position the stainless bail assembly

5. Internal Screen

Moulded conductive EPDM rubber to control electrical stress

6. Voltage test point

Provide means to check circuit status

7. Earthing Wire

To earth the external screen for the connector

8. Conductor Lug

To connect the cable conductor and probe

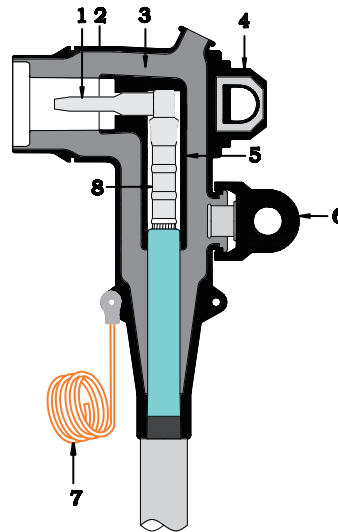

Up to 24kV
6/10(12) kV
6.35/11(12) kV
8.7/15(17.5) kV
12/20(24) kV
12.7/22(24) kV

Technical Data

Voltage Class	12kV	17.5kV	24kV
Continuous Current	250A	250A	250A
AC Withstand Voltage	28.5kV for 5min	39kV for 5min	54kV for 5min
Partial Discharge	11kV, ≤10pC	15kV, ≤10pC	20kV, ≤10pC
Impulse Withstand Voltage (10 times for each polarity)	95kV	95kV	125kV
Overload Current(8 hrs Max)	300A	300A	300A
Screen Resistance	≤5000Ω	≤5000Ω	≤5000Ω

Ordering instruction

The ordering formula as followed:

	1	2	3	4
WEZT				

Step 1

Choose the system voltage and current: 24/250

Step 2

Select the range from Table D that fits the diameter over core insulation

Step 3

Select the conductor code from Table C for the conductor size and type

Step 4

Select the package. 1: 1pc/kit; 3: 3pcs/kit.

Ordering example:

The cable is 24kV, 3-core 95mm² copper conductor with core insulation diameter of 22mm. Order **WEZT 24/250C05C3**.

Note:

Sealing or solderless grounding kits shall be ordered separately.

Feel free to contact us for detailed information.

Table D

Diameter over core insulation

Insulation Range Code	Diameter over core insulation ϕ (mm)	
	Min.	Max.
A	16	18
B	17	21
C	20	24
D	23.5	27

Table C

Conductor Code

Conductor Cross-section(mm ²)	Copper Conductor (Hexagonal compression)	Aluminium Conductor (Hexagonal compression)
25	01C	01B
35	02C	02B
50	03C	03B
70	04C	04B
95	05C	05B
120	06C	06B