



Cable GLANDS & Accessories
for Hazardous Application



Content

Cable Glands for Armoured cables E1RW Series	3 - 5
Cable Glands for Unarmoured cables RA2 Series	6 - 8
Accessories	9 - 11
Information on Ex	12
Certificates	13 - 14



NOMENCLATURE FOR ATEX CABLE GLANDS

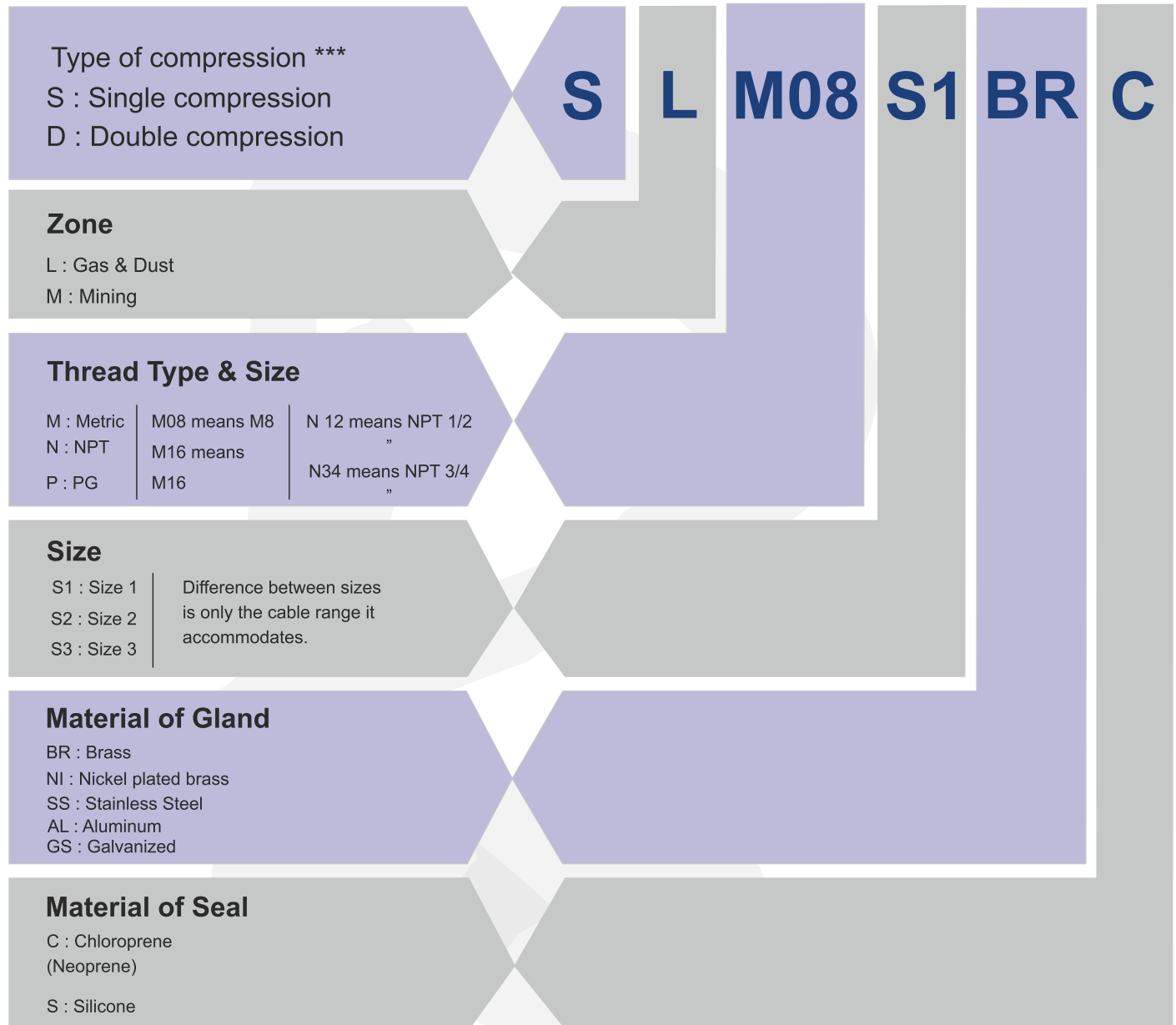



*** Single compression (S) : Our RA2 glands are Single compression (for cable without armour)

*** Double compression (D) : Our E1RW glands are Double compression (for armoured cables)

DOUBLE COMPRESSION CABLE GLAND FOR ARMoured CABLES

E1RW - SERIES

Approved by	CESI S.p.A		CESI S.p.A	
Examination Certificate Number	15 ATEX 058X		IECEX CES 15.0020X	
Date of issue	30/11/2015		18/12/2015	
Safety Requirements	EN 60079-0:2012		IEC 60079-0:2011 Edition:6.0	
	EN 60079-1:2007		IEC 60079-1:2007-04 Edition:6.0	
	EN 60079-7:2007		IEC 60079-31:2008- Edition:1	
	EN 60079-31:2009		IEC 60079-7:2006-07 Edition:4.0	
Equipment Marking		Ex d IIC Gb		Ex d IIC Gb
		Ex e IIC Gb		Ex e IIC Gb
		Ex tb IIIC Db		Ex tb IIIC Db
		IP 66/68		IP 66/68



Item	Item Description
1	O-ring BIS
2	Cone body
3	Displacement washer
4	O-ring DC
5	Detachable cone
6	Retainer ring
7	O-ring SR
8	Main body
9	Compression washer
10	Entry nut
11	Armour
12	Armour cable

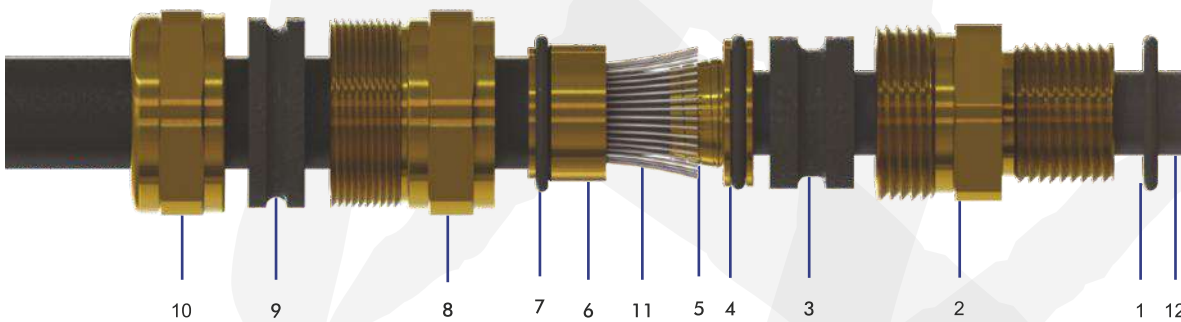

(Diagram - 1 - a)

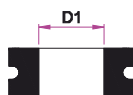

Upper Seal Cable
Outer Diameters

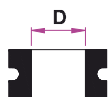

Lower Seal Cable
Inner Diameters

(Diagram - 1 - b)

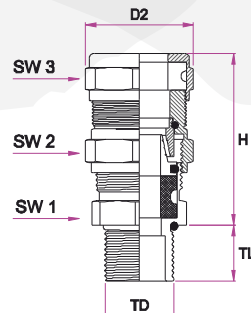

(Diagram - 1 - c)

E1RW - METRIC

Equipment	Gas Group	Dust Group
	Zone 1 / Zone 2	Zone 21 / Zone 22
Suitable for use	Group II	Group III
	Gas Group IIC	Dust Group IIIC
For	Gas & Dust potentially explosive atmospheres	
Level of Ingress Protection	IP 66 / 68	
Marking	RRPL EIRW CE 0539 II2GD Ex d IIC Gb / Ex e IIC Gb Ex tb IIIC Db IP 66/68 -60° to +130° CESI 15AATEX 058X / IECEx CES 15.0020X	
Cable Type	SWA - AWA	
Seal Operating Temperature	Chloroprene (Neoprene)	-40°C +100°C
	Silicon	-60°C +130°C
Material	Brass, Stainless steel, Nickel plated Brass, Galvanized steel	Item 2-5-6-8-10 (Dig.-1-a)
Thread type	Metric (M) ISO Pitch 1.5 NPT (N) ANSI ASME B1.20.1 Other thread type also available upon request.	

Thread Type	E1RW Cable Gland Code	Clamping Range (mm) Ø min-max (Dig.-1-b)		Cable Gland Dimensions (Dig. - 1-c)						Armor Wire Ø (mm)
		D (mm)	D1 (mm)	H min (mm)	TL min (mm)	SW1 (mm)	SW2 (mm)	SW3 (mm)	D2 min (mm)	
M16x1.5	DLM16S1BRC	3 - 8.5	6 - 12	47.5	16	22	26	26	29	0.7 - 1.2
M16x1.5	DLM16S2BRC	6 - 12	8.5 - 16	50	16	25	29	29	31.5	0.7 - 1.2
M20x1.5	DLM20S1BRC	3 - 8.5	6 - 12	47.5	16	24	26	26	29	0.7 - 1.2
M20x1.5	DLM20S2BRC	6 - 12	8.5 - 16	49	16	25	29	29	31.5	0.7 - 1.2
M20x1.5	DLM20S3BRC	12 - 14.5	16 - 20	52	16	28	30	32	35	0.8 - 1.3
M25x1.5	DLM25X1BRC	3 - 8.5	6 - 12	47.5	16	29	26	26	29	1 - 1.6
M25x1.5	DLM25S1BRC	6 - 12	8.5 - 16	50.5	18	29	29	29	31.5	0.7 - 1.2
M25x1.5	DLM25S2BRC	12 - 16	16 - 21	54.5	18	32	34	34	37	0.8 - 1.3
M25x1.5	DLM25S3BRC	12 - 20	16 - 26	60.5	18	36	40	40	44	1 - 1.6
M32x1.5	DLM32X1BRC	6 - 12	8.5 - 16	50.5	18	36	29	29	31.5	1 - 1.8
M32x1.5	DLM32S1BRC	12 - 20	16 - 26	62	18	40	40	40	44	1 - 1.6
M32x1.5	DLM32S2BRC	15 - 26	20 - 33	78.5	18	48	52	52	57	1 - 1.8
M40x1.5	DLM40X1BRC	12 - 20	16 - 26	62	18	45	40	40	44	1 - 1.8
M40x1.5	DLM40S1BRC	15 - 26	20 - 33	78.5	18	48	52	52	57	1 - 1.8
M40x1.5	DLM40S2BRC	20 - 32	29 - 41	89.5	18	55	60	60	66	1.5 - 2.2
M50x1.5	DLM50X1BRC	15 - 26	20 - 33	78.4	18	54	52	52	57	2 - 2.7
M50x1.5	DLM50X2BRC	20 - 32	29 - 41	88.7	18	55	60	60	66	2 - 2.7
M50x1.5	DLM50S1BRC	22 - 35	33 - 48	96.5	18	60	70	75	82	2 - 2.7
M50x1.5	DLM50S2BRC	27 - 41	36 - 52	100	18	70	70	74	83	2 - 2.7
M63x1.5	DLM63X1BRC	22 - 35	33 - 48	96.5	18	68	70	75	82	2 - 3
M63x1.5	DLM63X2BRC	27 - 41	36 - 52	100	18	70	70	74	83	2 - 3
M63x1.5	DLM63S1BRC	35 - 45	43 - 57	106	20	75	80	80	89.5	2.5 - 3.5
M63x1.5	DLM63S2BRC	40 - 52	47 - 60	108	20	85	85	85	94	2 - 3
M75x1.5	DLM75X1BRC	35 - 45	43 - 57	105.5	20	80	80	80	89.5	1.8 - 3
M75x1.5	DLM75S1BRC	40 - 52	47 - 60	108	20	85	85	85	94	2 - 3
M75x1.5	DLM75S2BRC	45 - 60	54 - 70	125	20	90	95	100	110.5	1.8 - 3
M90x1.5	DLM90X1BRC	40 - 52	47 - 60	108	20	95	85	85	94	1.8 - 3.5
M90x1.5	DLM90S1BRC	45 - 60	54 - 70	124	20	95	95	100	110.5	1.8 - 3
M90x1.5	DLM90S2BRC	60 - 72	63 - 80	154	20	110	115	115	127	1.8 - 3.5
M110x1.5	DLM1101BRC	45 - 60	54 - 70	124	20	110	95	100	110.5	1.8 - 3.5
M110x1.5	DLM1102BRC	60 - 72	63 - 80	154	20	110	115	115	127	1.8 - 3.5



E1RW - NPT

Equipment	Gas Group		Dust Group
	Zone 1 / Zone 2		Zone 21 / Zone 22
Suitable for use	Group II		Group III
	Gas Group IIC		Dust Group IIIC
For	Gas & Dust potentially explosive atmospheres		
Level of Ingress Protection	IP 66 / 68		
Marking	RRPL EIRW CE 0539 II2GD Ex d IIC Gb/ Ex e IIC Gb Ex tb IIIC Db IP 66/68 -60° to +130° CESA 15A ATEX 058X / IECEx CES 15.0020X		
Cable Type	SWA - AWA		
Seal Operating Temperature	Chloroprene (Neoprene)	-40°C +100°C	
	Silicone	-60°C +130°C	
Material	Brass, Stainless steel, Nickel plated Brass, Galvanized steel		Item 1-3-4-7-9 (Dig.-1-a) Item 2-5-6-8-10 (Dig.-1-a)
Thread type	Metric (M) ISO Pitch 1.5 NPT (N) ANSI ASME B1.20.1 Other thread type also available upon request.		

Thread Type	E1RW Cable Gland Code	Clamping Range (mm) Ø min-max (Dig-1-b)		Cable Gland Dimensions (Dig.-1-C)						Armor Wire Ø mm
		D mm	D1 min	H min (mm)	TL min (mm)	SW 1 (mm)	SW 2 (mm)	SW 3 (mm)	D2 min (mm)	
NPT3/8"	DLN38S1BRC	3 - 8.5	6 - 12	47.5	16	22	26	26	29	0.7-1.2
NPT3/8"	DLN38S2BRC	6 - 12	8.5 - 16	50	16	25	29	29	31.5	0.7 - 1.2
NPT1/2"	DLN12S1BRC	3 - 8.5	6 -12	47.5	16	24	26	26	29	0.7 - 1.2
NPT1/2"	DLN12S2BRC	6 - 12	8.5 - 16	49	16	25	29	29	31.5	0.7 - 1.2
NPT1/2"	DLN12S3BRC	12 - 14.5	16 - 20	52	16	28	30	32	35	0.8 - 1.2
NPT 3/4"	DLN34X1BRC	3 - 8.5	6 - 12	47.5	18	29	26	26	29	1 - 1.6
NPT3/4"	DLN34S1BRC	6 - 12	8.5 - 16	50.5	18	29	29	29	31.5	0.7 - 1.2
NPT3/4"	DLN34S2BRC	12 - 16	16 - 21	54.5	18	32	34	34	37	0.8 - 1.2
NPT3/4"	DLN34S3BRC	12 - 20	16 - 26	60.5	21	36	40	40	44	1 - 1.6
NPT1"	DLN01X1BRC	6 - 12	8.5 - 16	50.5	21	36	29	29	31.5	1 - 1.8
NPT1"	DLN01S1BRC	12 - 20	16 - 26	62	21	40	40	40	44	1 - 1.6
NPT1"	DLN01S2BRC	15 - 26	20 - 33	78.5	21	48	52	52	57	1 - 1.8
NPT1 1/4"	DLN114X1BRC	12 - 20	16 - 26	62	21	45	40	40	44	1 - 1.8
NPT1 1/4"	DLN1141BRC	15 - 26	20 - 33	78.5	21	48	52	52	57	1 - 1.8
NPT1 1/4"	DLN1142BRC	20 - 32	29 - 41	89.5	18	55	60	60	66	1.5 - 2.2
NPT1 1/2"	DLN112X1BRC	15 - 26	20 - 33	78.4	21	54	52	52	57	2 - 2.7
NPT1 1/2"	DLN112X2BRC	20 - 32	29 - 41	88.7	21	55	60	60	66	2 - 2.7
NPT1 1/2"	DLN1121BRC	22 - 35	33 - 48	96.5	21	60	70	75	82	2 - 2.7
NPT1 1/2"	DLN1122BRC	27 - 41	36 - 52	100	21	70	70	74	83	2 - 2.7
NPT2"	DLN02X1BRC	22 - 35	33 - 48	96.5	20	68	70	75	82	2 - 3
NPT2"	DLN02X2BRC	27 - 41	36 - 52	100	20	70	70	74	83	2 - 3
NPT2"	DLN02S1BRC	35 - 45	43 - 57	106	21	75	80	80	89.5	2.5 - 3.5
NPT2"	DLN02S2BRC	40 - 52	47 - 60	108	20	85	85	85	94	2-3
NPT2 1/2"	DLN212X1BRC	35 - 45	43 - 57	105.5	21	80	80	80	89.5	1.8 - 3
NPT2 1/2"	DLN2121BRC	40 - 52	47 - 60	108	21	85	85	85	94	2 - 3
NPT2 1/2"	DLN2122BRC	45 - 60	54 - 70	125	20	90	95	100	110.5	1.8 - 3
NPT3"	DLN03X1BRC	40 - 52	47 - 60	108	21	95	85	85	94	1.8 - 3.5
NPT3"	DLN03S1BRC	45 - 60	54 - 70	124	21	95	95	100	110.5	1.8 - 3
NPT3"	DLN03S2BRC	60 - 72	63 - 80	154	21	110	115	115	127	1.8 - 3.5
NPT 3 1/2"	DLN3121BRC	45 - 60	54 - 70	124	21	110	95	100	110.5	1.8 - 3.5
NPT 3 1/2"	DLN3122BRC	60 - 72	63 - 80	154	21	110	115	115	127	1.8 - 3.5

SINGLE COMPRESSION GLAND FOR UNARMoured CABLES

RA2 - SERIES

Approved by	IMQ	IMQ		
Examination Certificate Number	IMQ 15 ATEX 016X	IECEX 15 IMQ 15.008X		
Date of issue	17/12/2015	16/12/2015		
Safety Requirements	EN 60079-0:2009	IEC 60079-0:2007 Edition: 5		
	EN 60079-7:2007	IEC 60079-7:2006-07 Edition:4.0		
	EN 60079-31:2009	IEC 60079-31:2008- Edition:1		
Equipment Marking		Ex d IIC Gb		Ex d IIC Gb
		Ex e IIC Gb		Ex e IIC Gb
		Ex tb IIIC Db		Ex tb IIIC Db
		IP 66/68		IP 66/68



Item	Item Description
1	O-ring
2	Cone body
3	Seal S3
4	Seal S2
5	Seal S1
6	Entry nut
7	Cable

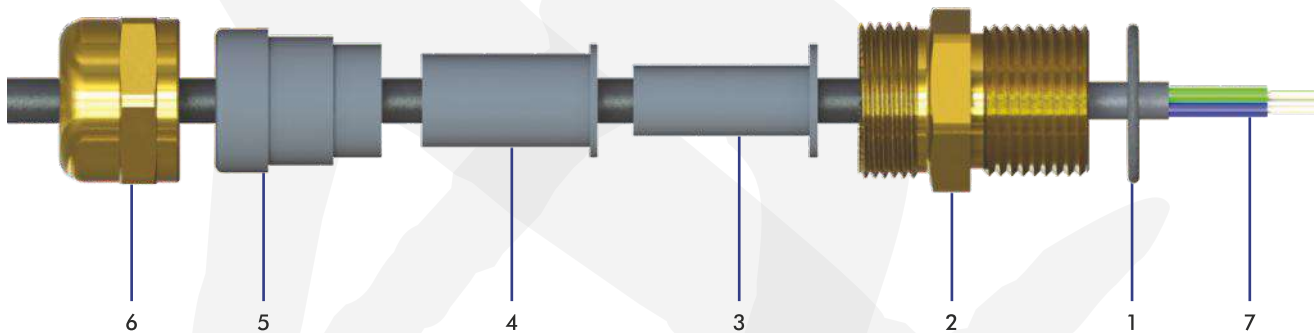

(Diagram - 2 - a)

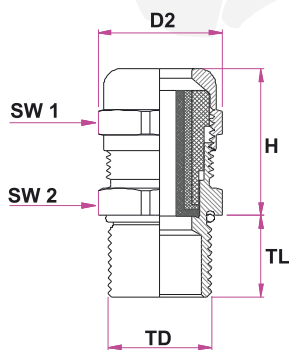

(Diagram - 2 - b)

Clamping Range (D)
Sealing Combinations

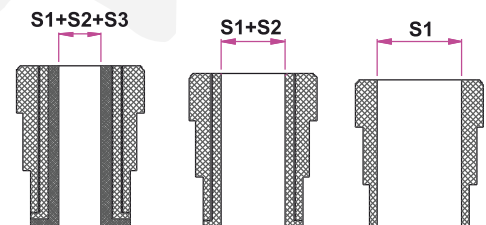

(Diagram - 2 - c)

RA2 - METRIC

Equipment	Gas Group		Dust Group
	Zone 1 / Zone 2		Zone 21 / Zone 22
Suitable for use	Group II		Group III
	Gas Group IIC		Dust Group IIIC
For	Gas & Dust potentially explosive atmospheres		
Level of Ingress Protection	IP 66 / 68		
Marking	RRPL RA2 0539 II 2GD Ex d IIC Gb Ex e IIC Gb Ex tb IIIC Db IP66/68 -40° to +140°C IMQ 15 ATEX 016X /IECEX 15 IMQ 15.0008X		
Cable Type	Unarmoured		
Seal Operating Temperature	Chloroprene (Neoprene)	-40°C /+80°C	Item 1-3-4-5 (Dig.-2-a)
	Silicone	-60°C /+ 140°C	
Material	Brass, Stainless steel, Aluminum Nickel plated Brass, Steel		Item 2-6 (Dig.-2-a)
Thread type	Metric (M) ISO Pitch 1.5 NPT (N) ANSI ASME B1.20.1 Other thread type also available		

Thread Type	RA2 Cable Gland code	Clamping Range (mm) Ø min-max (Dig-3-c)				Cable Gland Dimensions				
		D (mm)	S1+S2+S3 (mm)	S1+S2 (mm)	S1 (mm)	H MiM (mm)	TL (mm)	SW1 (mm)	SW2 (mm)	D2 (mm)
*M8x1.5	SLM08S1BRC	2 - 4	-	-	2 - 4	15.5	5	11	11	12
*M12x1.5	SLM12S1BRC	4 - 8	4 - 6	6 - 8	-	14.5	16	22	22	24.5
M16x1.5	SLM16S1BRC	3 - 9	-	3 - 6	6 - 9	11	16	20	20	24.5
M16x1.5	SLM16S2BRC	4 - 12	4 - 6	6 - 9	9 - 12	24	16	22	22	24.5
M20x1.5	SLM20S0BRC	3 - 9	-	3 - 6	6 - 9	11	16	20	20	24.5
M20x1.5	SLM20S1BRC	4 - 12	4 - 6	6 - 9	9 - 12	24	16	22	22	24.5
M20x1.5	SLM20S2BRC	10 - 16	10 - 12	12 - 14.5	14.5 - 16	29	16	28	28	31
M25x1.5	SLM25S1BRC	10 - 18	10 - 12	12 - 14.5	14.5 - 18	24	16	28	28	31
M25x1.5	SLM25S2BRC	14 - 20	14 - 17	17 - 20	-	34	16	35	35	39
M32x1.5	SLM32S1BRC	14 - 24	14 - 17	17 - 20	20 - 24	27	16	35	35	39
M32x1.5	SLM32S2BRC	22 - 28	22 - 24	24 - 27	27 - 28	37	16	45	45	49.5
M40x1.5	SLM40S1BRC	22 - 32	22 - 24	24 - 27	27 - 32	27	18	45	45	49.5
M40x1.5	SLM40S2BRC	26 - 34	26 - 28	28 - 31	31 - 34	37	18	50	50	56
M50x1.5	SLM50S1BRC	26 - 35	26 - 28	28 - 31	31 - 35	28	18	50	55	56
M50x1.5	SLM50S2BRC	35 - 44	35 - 38	38 - 41	41 - 44	45	18	64	64	70
M63x1.5	SLM63S1BRC	35 - 45	35 - 38	38 - 41	41 - 45	35	18	64	68	70
M63x1.5	SLM63S2BRC	46 - 56	46 - 48	48 - 52	52 - 56	44	18	80	75	89
M75x1.5	SLM75S1BRC	46 - 62	46 - 51	51-57	57 - 62	44	20	80	80	89
M75x1.5	SLM75S2BRC	60 - 70	60 - 63	63 - 69	69 - 70	55	20	95	95	105
M90x1.5	SLM90S1BRC	60 - 70	60 - 63	63 - 69	69 - 70	55	20	95	95	105
M90x1.5	SLM90S2BRC	75 - 85	75 - 79	79 - 82	82 - 85	57	20	105	105	117
M100x1.5	SLM1001BRC	75 - 85	75 - 79	79 - 82	82 - 85	57	20	105	105	117
M110x1.5	SLM1102BRC	85 - 95	85 - 89	89 - 92	92 - 95	57	20	115	115	129

* only Ex e IIC Gb / Ex tb IIIC Db

RA2 - NPT

Equipment	Gas Group	Dust Group
	Zone 1 / Zone 2	Zone 21 / Zone 22
Suitable for use	Group II	Group III
	Gas Group IIC	Dust Group IIIC
For	Gas & Dust potentially explosive atmospheres	
Level of Ingress Protection	IP 66 / 68	
Marking	RRPL RA2 CE 0539 II 2GD Ex d IIC Gb Ex e IIC Gb Ex tb IIIC Db IP66/68 -40° to +140°C IMQ 15 ATEX 016X /IECEx 15 IMQ 15.0008X	
Cable Type	Unarmoured	
Seal Operating Temperature	Chloroprene (Neoprene)	Item 1-3-4-5 (Dig.-3-a)
	Silicone	
Material	Brass, Stainless steel, Aluminum, Nickel plated, Brass steel	Item 2-6 (Dig.-3-a)
Thread type	Metric (M) ISO Pitch 1.5 NPT (N) ANSI ASME B1.20.1 Other thread type also available	

Thread Type	RA2 Cable Gland code	Clamping Range (mm) Ø min-max (Dig-2-c)				Cable Gland Dimensions (Dig.-2-b)				
		D (mm)	S1+S2+S3 (mm)	S1+S2 (mm)	S1 (mm)	H MiM (mm)	TL (mm)	SW1 (mm)	SW2 (mm)	D2 (mm)
*NPT1/4"	SLN14S1BRC	4 - 8	4 - 6	6 - 8	-	14.5	16	22	22	24.5
NPT3/8"	SLN38S1BRC	3 - 9	-	3 - 6	6 - 9	11	16	20	20	24.5
NPT3/8"	SLN38S2BRC	4 - 12	4 - 6	6 - 9	9 - 12	14.5	16	22	22	24.5
NPT1/2"	SLN12S0BRC	3 - 9	-	3 - 6	6 - 9	11	16	20	20	24.5
NPT1/2"	SLN12S1BRC	4 - 12	4 - 6	6 - 9	9 - 12	26.5	16	22	22	24.5
NPT1/2"	SLN12S2BRC	10 - 16	10 - 12	12 - 14.5	14.5 - 16	30	16	28	28	31
NPT3/4"	SLN34S1BRC	10 - 18	10 - 12	12 - 14	514.5 - 18	30	16	28	28	31
NPT3/4"	SLN34S2BRC	14 - 20	14 - 17	17 - 20	-	33	16	35	35	39
NPT1"	SLN01S1BRC	14 - 24	14 - 17	17 - 20	20 - 24	33.5	20	35	35	39
NPT1"	SLN01S2BRC	22 - 26	22 - 24	24 - 26	-	40	20	45	45	49.5
NPT1 1/4"	SLN1141BRC	22 - 32	22 - 24	24 - 27	27 - 32	40.5	20	45	45	49.5
NPT1 1/4"	SLN1142BRC	26 - 34	26 - 28	28 - 31	31 - 34	43.5	20	50	50	56
NPT1 1/2"	SLN1121BRC	26 - 35	26 - 28	28 - 31	31 - 35	42.5	20	50	55	56
NPT1 1/2"	SLN1122BRC	35 - 41	35 - 38	38 - 41	-	42.5	20	64	64	70
NPT2"	SLN02S1BRC	35 - 45.03	5 - 38	38 - 41	41 - 45	43.5	20	64	68	70
NPT2"	SLN02S2BRC	46 - 56	46 - 48	48 - 52	52 - 56	52.5	20	80	75	89
NPT2 1/2"	SLN2121BRC	46 - 62	46 - 51	51 - 57	57 - 62	52	21	80	80	89
NPT2 1/2"	SLN2122BRC	60 - 70	60 - 63	63 - 69	69 - 70	55	21	95	95	105
NPT3"	SLN03S1BRC	60 - 70	60 - 63	63 - 69	69 - 70	55	21	95	95	105
NPT3"	SLN03S2BRC	75 - 85	75 - 79	79 - 82	82 - 85	54.5	21	105	105	117
NPT4"	SLN04S1BRC	75 - 85	75 - 79	79 - 82	82 - 85	54.5	21	105	115	117
NPT4"	SLN04S2BRC	85 - 95	85 - 89	89 - 92	92 - 95	56	21	115	115	129

* only Ex e IIC Gb / Ex tb IIIC Db

ACCESSORIES

Earth Tag

Material		Brass / Nickel Plated Brass / Stainless Steel						
Type	Earth tag code	Dimensions (Dig.-8)						
		AØ (mm)	E (mm)	CØ (mm)	DØ (mm)	E (mm)	F (mm)	G (mm)
M12	REM12S1BR	12.20	1.5	22	6.2	46	30	12
M16	REM16S1BR	16.20	1.5	25	6.2	48.75	30	12.5
M20	REM20S1BR	20.20	1.5	28.6	6.2	53.55	33	12.5
M25	REM25S1BR	25.20	1.5	34	6.2	59.50	36	13
M32	REM32S1BR	32.20	1.5	42	12.2	73	41	22
M40	REM40S1BR	40.20	1.5	54	14.2	86.50	46.5	26
M50	REM50S1BR	50.20	1.5	67	14.2	111.50	63.5	29
M63	REM63S1BR	63.20	1.5	77	14.2	125.50	72.5	29
M75	REM75S1BR	75.20	1.5	89	14.2	137.50	77	32
M80	REM80S1BR	80.20	1.5	100	14.2	158	91.5	32
M90	REM90S1BR	90.20	1.5	109.5	14.2	167	94.5	35.5
M110	REM1101BR	110.20	1.5	138	14.2	214	125	40
NPT 1/4"	REN14S1BR	13.50	1.5	22	6.2	46	30	12
NPT 3/8"	REN38S1BR	17.35	1.5	25	6.2	48.75	30	12.5
NPT 1/2"	REN12S1BR	21.70	1.5	28.6	6.2	53.55	33	12.5
NPT 3/4"	REN34S1BR	26.90	1.5	34	6.2	59.50	36	13
NPT 1"	REN01S1BR	33.60	1.5	42	12.2	73	41	22
NPT 1 1/4"	REN1141BR	42.35	1.5	54	14.2	86.50	46.5	26
NPT 1 1/2"	REN1121BR	48.50	1.5	67	14.2	111.50	63.5	29
NPT 2"	REN02S1BR	60.50	1.5	77	14.2	125.50	72.5	29

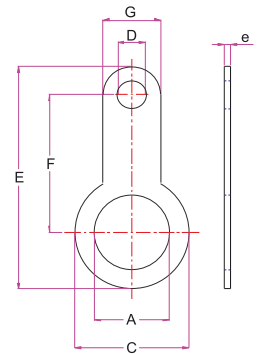

Ordering information: For Nickel plated replace BR with Ni and for Stainless Steel replace BR with SS.

Shrouds

Shrouds Code	Dimensions	
	Ø D mm	H mm
RSM16S1P (3.0-8.5)	29.1	67
RSM16S2P (6.0-12.0)	31.7	68
RSM20S1P (3.0-8.5)	29.1	67
RSM20S2P (6.0-12.0)	31.7	68
RSM20S3P (8.5-14.5)	35.2	76.6
RSM25S1P (6.0-12.0)	31.7	68
RSM25S2P (8.5-16.0)	37.2	78.6
RSM25S3P (12.0-20.0)	44.2	81.6
RSM32S1P (12.0-20.0)	44.2	81.6
RSM32S2P (15.0-26.0)	57.2	112
RSM40S1P (15.0-26.0)	57.2	112
RSM40S2P (20.0-32.0)	66.2	117.1
RSM50S1P (22.0-35.0)	82.2	132.6
RSM50S2P (27.0-41.0)	83.2	132.6
RSM63S1P (35.0-45.0)	89.7	148
RSM63S2P (40.0-52.0)	94.2	143.8
RSM75S1P (40.0-52.0)	94.2	143.8
RSM90S1P (45.0-60.0)	110.6	182.7

Code	Dimensions	
	Ø D mm	H mm
RSM16S1P (3.0-12.0)	24.5	56.1
RSM20S1P (3.0-12.0)	24.5	56.1
RSM20S2P (10.0-18.0)	31	67.5
RSM25S1P (10.0-18.0)	31	67.5
RSM25S2P (14.0-24.0)	39	72.6
RSM32S1P (14.0-24.0)	39	72.6
RSM32S2P (22.0-32.0)	49.5	91.7
RSM40S1P (22.0-32.0)	49.5	91.7
RSM40S2P (26.0-34.0)	56.1	88
RSM50S1P (26.0-35.0)	61	88
RSM50S2P (35.0-44.0)	70.1	93.9
RSM63S1P (35.0-45.0)	74.9	95.5
RSM63S2P (46.0-56.0)	89	100.8
RSM75S1P (46.0-62.0)	89	100.8

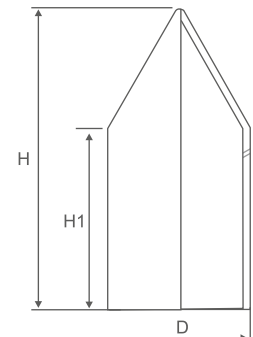

ACCESSORIES

Lock Nuts

Material	Brass / Nickel Plated Brass / Stainless Steel			
Thread Type	Code	Metal		
		Dimensions		
		H (mm)	SW (mm)	D (mm)
M12x1.5	RLM12S1BR	2.8	15	16.6
M16x1.5	RLM16S1BR	3	19	21
M20x1.5	RLM20S1BR	3.5	24	26.5
M25x1.5	RLM25S1BR	4	30	33
M32x1.5	RLM32S1BR	5	36	39.5
M40x1.5	RLM40S1BR	5	46	51
M50x1.5	RLM50S1BR	5	60	66
M63x1.5	RLM63S1BR	6	70	77
M75x1.5	RLM75S1BR	7	80	89
M90x1.5	RLM90S1BR	8	100	112
M100x1.5	RLM100S1BR	10	110	124
M110x1.5	RLM110S1BR	10	120	135

Ordering Information: For Nickel Plated replace BR with NI and for Stainless Steel replace BR with SS.

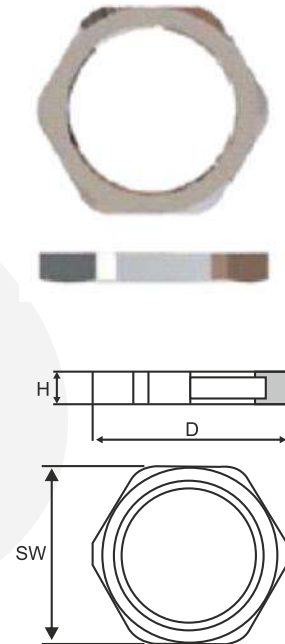

Gaskets

Material	Chloroprene -40°C +100°C Silicon -60°C +180°C			
	Code	Dimensions		
		S (mm)	D (mm)	d (mm)
M12	RGM12S1C	1.5	15.5	10.3
M16	RGM16S1C	1.5	21.5	15.5
M20	RGM20S1C	1.5	26	18.5
M25	RGM25S1C	1.5	31.5	23.3
M32	RGM32S1C	1.5	38.5	30.5
M40	RGM40S1C	1.5	48.5	38.5
M50	RGM50S1C	1.5	58	48
M63	RGM63S1C	1.5	70	61.2
M75	RGM75S1C	1.5	86	74.5
M90	RGM90S1C	1.5	102	89.5
M110	RGM1101C	1.5	123	109.5

Ordering Information: For Silicon replace C with Si

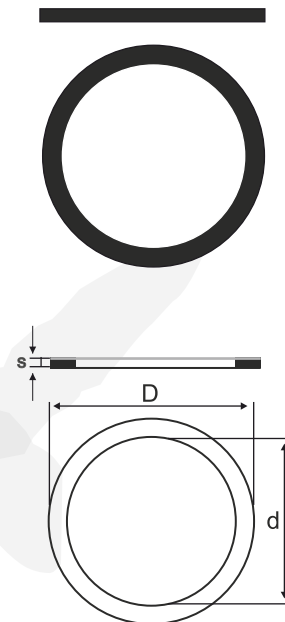

ACCESSORIES

Washer Polyamide

Material		Polyamide 6 (PA)		
Size	WASHER Code	Dimensions		
		S (mm)	D (mm)	d (mm)
M20	RWM20S1PA	1.5	23.8	19.7
M25	RWM25S1PA	1.5	32.2	24.7
M32	RWM32S1PA	1.5	39.6	31.7
M40	RWM40S1PA	1.5	49.6	39.7
M50	RWM50S1PA	1.5	62	49.7
M63	RWM63S1PA	1.5	78.4	62.7
M75	RWM75S1PA	1.5	93.4	74.7
M90	RWM90S1PA	1.5	112	89.7
M110	RWM110S1PA	1.5	124.6	99.7

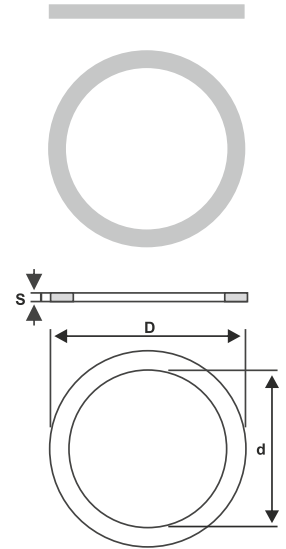

Washer Serrated

Material		Brass / Nickel Plated Brass / Stainless Steel			
Size		Code	Dimensions		
			S (mm)	D (mm)	d (mm)
M12	NPT 1/4"	RSWM12S1BR	1.5	18	12.2
M16	NPT 3/8"	RSWM16S1BR	1.5	24	16.2
M20	NPT 1/2"	RSWM20S1BR	1.5	30	20.2
M25	NPT 3/4"	RSWM25S1BR	1.5	38	25.3
M32	NPT 1"	RSWM32S1BR	1.5	48	32.3
M40	NPT 1 1/4"	RSWM40S1BR	1.5	60	40.3
M50	NPT 1 1/2"	RSWM50S1BR	1.5	75	50.3
M63	NPT 2"	RSWM63S1BR	1.5	95	63.4
M75	NPT 2 1/2"	RSWM75S1BR	2.0	112	75.4
M90	NPT 3"	RSWM90S1BR	2.0	135	90.4
M110	NPT 4"	RSWM110S1BR	2.5	154	110.4

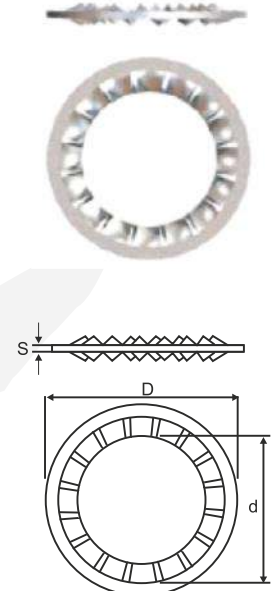

Ordering Information: For Stainless Steel replace BR with SS and for Nickel Plated Brass replace BR with NI

EXPLOSION PROOF INFORMATION

Fire Explosion Triangle

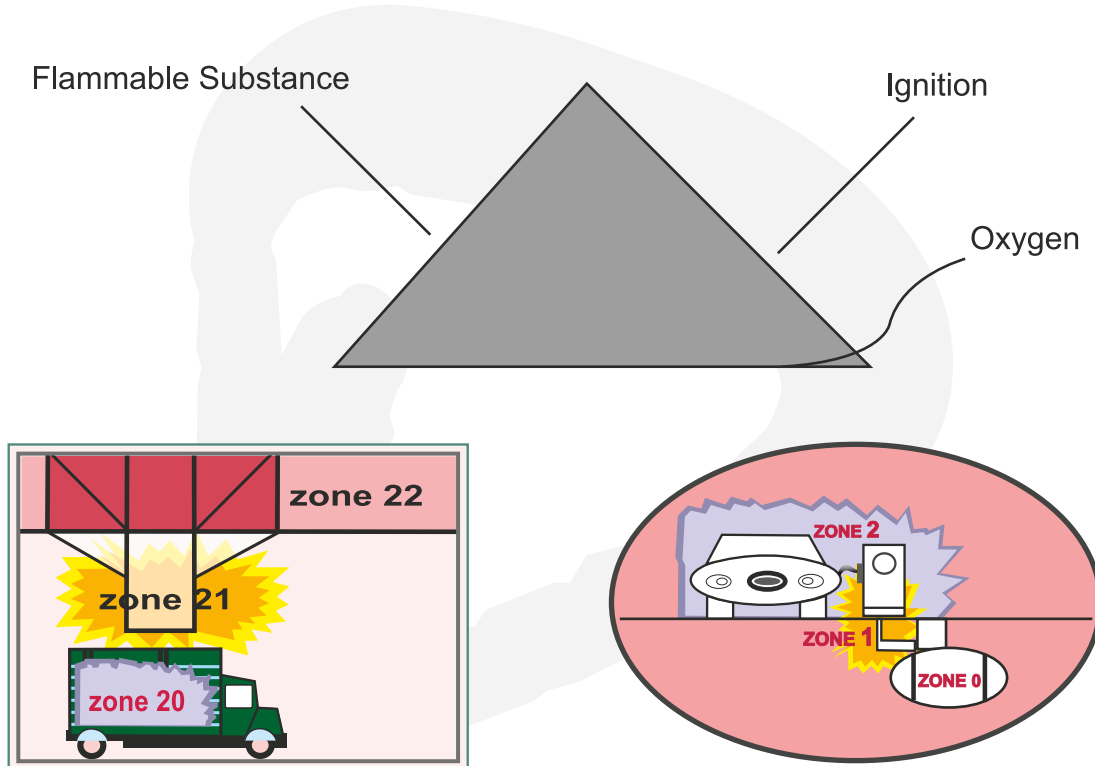

CABLE GLANDS FOR EX HAZARDOUS AREAS

Raychem RPG manufactures cable glands suitable for Ex Hazardous areas in which flammable substances (Oil & Gas) substantially exist in atmosphere, hence the potentially explosive atmospheres.

Our cable glands are suitable & compatible for the equipment/enclosures/junction boxes with the Equipment Protection up to Ex d, Ex e and Ex tb.

Equipment Protection	Description
Ex d: Flame proof/Explosion proof	Type of Equipment Protection in which parts (can ignite explosive atmospheres) to be placed in enclosure, which can withstand pressure developed during internal explosion and prevents the transmission of explosion to explosive gas atmosphere surrounding the enclosure.
Ex e: Increased safety	Type of equipment protection in which additional measures are applied so as to give increased security against the possibility of excessive temperatures and of the occurrence of arcs and sparks.
Ex tb: Dust ignition protection by enclosure	Type of equipment protection for explosive dust atmospheres where electrical equipment is provided with an enclosure providing dust ingress protection and means to limit surface temperatures.

CERTIFICATION FOR E1RW





CEI S.p.A.
Via Rubattino 54
I-20134 Milano - Italy
Tel. +39 02 21251
Fax +39 02 71252440
Central Warehouse
www.cesi.it

CERTIFICATE



EC-TYPE EXAMINATION CERTIFICATE

[1] Equipment or Protective System intended for use in potentially explosive atmospheres.
Directive 94/9/EC

[2] EC-Type Examination Certificate number:
CESI 15 ATEX 058 X

[4] Equipment: Cable glands series DL, DL-LT (E1RW) and UL, UL-LT (E1RU)

[5] Manufacturer: Raychem RPG Pvt Ltd.

[6] Address: Cest Mahal Annave 463, Dr. Annie Besant Road Mumbai 400025, India

[7] This equipment or protective system and any acceptable variation thereto is specified in the schedule to this certificate and the documents therein referred to.

[8] CESI, notified body n. 0722 in accordance with Article 9 of the Council Directive 94/9/EC of 23 March 1994, certifies that this equipment or protective system has been found to comply with the Essential Health and Safety Requirements relating to the design and construction of equipment and protective systems intended for use in potentially explosive atmospheres given in Annex I] to the Directive.
The examination and test results are recorded in confidential report n. EX-B5023773.

[9] Compliance with the Essential Health and Safety Requirements has been assured by compliance with:
EN 60079-0:2012 EN 60079-1:2007 EN 60079-7:2007 EN 60079-31:2009

[10] If the sign "X" is placed after the certificate number, it indicates that the equipment or protective system is subject to special conditions for safe use specified in the schedule to this certificate.

[11] This EC-TYPE EXAMINATION CERTIFICATE relates only to the design, examination and tests of the specified equipment or protective system in accordance to the Directive 94/9/EC. Further requirements of the Directive apply to the manufacturing process and supply of this equipment or protective system. These are not covered by this certificate.

[12] The marking of the equipment or protective system shall include the following:



II 2GD Ex d IIC Gb and Ex e IIC Gb and Ex tb IIC Db IP66/68

This certificate may only be reproduced in its entirety and without any change, schedule included.

Date 2015.11.30 - Translation issued the 2015.11.30

Prepared
Alessandro Fedato



Verified
Mirko Balaz



Approved
Roberto Piccin





Page 1/6

Schema di certificazione

CESI-ATEX



PRD N. 0116
Verbo del Accordo di Riconoscimento di Competenza in Italia
Sottoscritto da: CEI e ACCREDIA

IECEx Certificate of Conformity

INTERNATIONAL ELECTROTECHNICAL COMMISSION
IEC Certification Scheme for Explosive Atmospheres

for rules and details of the IECEx Scheme visit www.iecex.com

Certificate No.:	IECEx CES 15.0020X	Issue No: 0	Certificate history: Issue No. 0 (2015-12-16)
Status:	Current	Page 1 of 3	
Date of Issue:	2016-12-18		
Applicant:	Raychem RPG Pvt Ltd. Cest Mahal Annave 463 Dr. Annie Besant Road Mumbai 400025 India		
Electrical Apparatus: Optional accessory:	Cable glands, type DL, DL-LT (E1RW) and UL, UL-LT (E1RU)		
Type of Protection:	Flameproof enclosures 'd', increased safety 'e', Dust ignition protection 'T'		
Marking:	Ex d IIC Gb Ex e IIC Gb Ex tb IIC Db IP 66/68		
Approved for issue on behalf of the IECEx Certification Body:	Mirko Balaz		
Position:	Head of IECEx CB		
Signature: (for printed version)	_____		
Date:	_____		





1. This certificate and schedule may only be reproduced in full.
2. This certificate is not transferable and remains the property of the issuing body.
3. The Status and authenticity of this certificate may be verified by visiting the Official IECEx Website.



Certificate issued by:

CESI
Centro Elettrotecnico
Spedimentale Italiana S.p.A.
Via Rubattino 54
20134 Milano
Italy



CERTIFICATION FOR RA2

 		Organismo autorizzato n. 0951 con D. M. 13 luglio 2005		Direzione / Issue of: 2015-12-17 Data di approvazione / updated as: Modifica / Update:
Certificato / Certificate				
[1]	Direttiva 94/9/CE Certificato di Esame CE del Tipo		Directive 94/9/EC EC-type Examination Certificate	
[2]	Apparecchiatura o sistema di protezione destinati ad essere utilizzati in atmosfere potenzialmente esplosive - Direttiva 94/9/CE / Equipment or protective system intended for use in potentially explosive atmospheres - Directive 94/9/EC			
[3]	Numero del Certificato di Esame CE del Tipo / EC-type Examination Certificate number IMQ 15 ATEX 016 X			
[4]	Apparecchiatura / Equipment Pressocavi metallici / Metal cable glands		Tipo / Type - Serie / Series RA2-SL...	
[5]	Costruttore / Manufacturer Raychem RPG Pvt. Ltd.		Indirizzo / Address Cost Malal Annex 463 Dr. Annie Besant Road Mumbai, 400025 - INDIA	
[7]	Questo apparecchio o sistema di protezione o le sue eventuali varianti accettabili sono descritti e realizzati in questo certificato e nei documenti descritti (vedi pagine riportate in esso)		The equipment or protective system and any acceptable variation thereof are specified in the schedule to this certificate and the documents therein referred to.	
[8]	L'IMQ, organismo notificato n. 0001, in conformità all'articolo 9 della Direttiva 94/9/CE del Consiglio dell'Unione Europea del 23 marzo 1994, certifica che questa apparecchiatura o sistema di protezione è conforme ai requisiti essenziali di sicurezza e salute per il progetto e la costruzione di apparecchiature o sistemi di protezione destinati ad essere utilizzati in atmosfere potenzialmente esplosive, definiti nel riferimento E della Direttiva. Le verifiche ed i risultati di prova sono riportati nel rapporto di carattere riservato n.		IMQ, notified body n. 0001, in accordance with Article 9 of the Council Directive 94/9/EC of 23 March 1994, certifies that the equipment or protective system has been found to comply with the Essential Health and Safety Requirements relating to the design and construction of equipment and protective systems intended for use in potentially explosive atmospheres given in Annex II to the Directive. The examination and test results are included in confidential report no.	
AT15AD526904-01				
[9]	La conformità ai Requisiti Essenziali di Sicurezza e Salute è assicurata dalla conformità alle:		Compliance with Essential Health and Safety Requirements has been assured by compliance with:	
EN 60079-0:2012; EN 60079-1:2014; EN 60079-7:2007; EN 60079-31:2014				
[10]	Il simbolo "C" (posto dopo il numero del certificato) indica che l'apparecchiatura o sistema di protezione è soggetto a condizioni speciali per un'ulteriore azione, specificata nell'aliquota al presente certificato.		If the sign "C" is placed after the certificate number, it indicates that the equipment or protective system is subject to special conditions for safe use specified in the schedule to this certificate.	
[11]	Questo CERTIFICATO CE ESAME CE DEL TIPO è relativo soltanto al progetto, all'analisi ed alle prove dell'apparecchiatura o sistema di protezione specificata in accordo con la Direttiva 94/9/CE. Ulteriori requisiti di questa Direttiva si applicano al processo di produzione e all'installazione dell'apparecchiatura o sistema di protezione. Questi requisiti non sono soggetti di presente certificato.		The EC-TYPE EXAMINATION CERTIFICATE relates only to the design, examination and tests of the specified equipment or protective system in accordance to the Directive 94/9/EC. Further requirements of the Directive apply to the manufacturing process and to supply of the equipment or protective system. These are not covered by the certificate.	
[12]	L'apparecchiatura o il sistema di protezione deve includere i seguenti contrassegni		The marking of the equipment or protective system shall include the following	
II 2GD Ex e IIC Gb; Ex d IIC Gb Ex tb IIC Db IP66/68				
				
				
Membri degli Azionisti di Mutualis/azionamento Dr. MF e B&B Signatory of IEC, IAF and IAC Mutual Recognition Agreement				
Questo certificato, allegato inclusa, può essere riprodotto solo integralmente e senza alcuna variazione. The certificate may only be reproduced in its entirety and without any change, schedule included.				
1/6 Mod. 10279				

 		IECEx Certificate of Conformity	
INTERNATIONAL ELECTROTECHNICAL COMMISSION IEC Certification Scheme for Explosive Atmospheres <small>for rules and details of the IECEx Scheme visit www.iecex.com</small>			
Certificate No.:	IECEx IMQ 15.0008X	Issue No. 0	Certificate History Issue No. 0 (2015-12-18)
Status:	Current	Page 1 of 3	
Date of Issue:	2015-12-16		
Applicant:	Raychem RPG Pvt. Ltd. Cost Malal Annex 463 Dr. Annie Besant Road Mumbai, 400025 India		
Electrical Apparatus: Optional accessory:	Metal cable glands for circular cables series RA2-SL...		
Type of Protection:	Ex d; Ex e; Ex tb		
Marking:	Ex d IIC Gb Ex e IIC Gb Ex tb IIC Db IP66/68		
Approved for issue on behalf of the IECEx Certification Body:	Mr. Mauro CASARI IMQ ExCB Manager		
Signature: (for printed version)	_____		
Date:	_____		
1. This certificate and schedule may only be reproduced in full. 2. This certificate is not transferable and remains the property of the issuing body. 3. The Status and authenticity of this certificate may be verified by visiting the Official IECEx Website.			
Certificate issued by: Istituto Italiano del Marchio di Qualità S.p.A. Via Quintiliano 43 20136 Milano, Italy			
			



Our Company

Raychem RPG (P) Ltd., incorporated in 1989, is a 50:50 Joint Venture between TE Connectivity, U.S.A. (formerly Tyco Electronics) and RPG Enterprises, India.

TE Connectivity is a US\$13 Billion global provider for Solutions in Network, Transportation, Consumers and Industrial for over 50 years.

RPG Enterprises, an establishment of over 30 years, is one of India's fastest growing business groups with turnover of US\$ 3 Billion. The group has more than fifteen companies managing diverse business interests in the areas of Automotive Tyres, Infrastructure, IT and Specialty including Pharmaceuticals, Power Ancillaries & Plantations.



Raychem RPG (P) Ltd.

Corporate Office

RPG House, 463, Dr. A. B. Road, Worli, Mumbai - 400030

Tel. : +91 22 24937485 / 24937486

Fax : +91 22 24938879

International Business Division (IBD) - EBU

1,62, M.G. Rd., Near Bharat Petroleum Pump,

Off. Western Express Highway, P. Satavali, Bassein, Taluka Vasai, Dist. Palghar

Tel. : +91 250 3057500

Fax : +91 250 2480046

Email : raychem@raychemrpg.com

www.raychemrpg.com



(A TE-Connectivity - RPG Enterprises JV)

Copyright 2017

All Rights Reserved to Raychem RPG (P) Limited
V.012017