

## Overload Relays Characteristics

### Environment

Conforming to standards			IEC 60947-1, IEC 60947-4-1, NFCEN 60947-4-1, VDE 0660, BSEN 60947
Approvals			UL, CSA, IEC
Degree of protection	Conforming to VDE 0106		Protection against direct finger contact IP 2X
Protective treatment	Conforming to IEC 68		"TH"
Ambient air temperature (around the device)	Storage	°C	-60 to +70
	Operation, without derating	°C	-25 to +60
	Max. & Min. operating temp.	°C	-40 to +70
Shock resistance	Permissible acceleration		15gn - 11ms, conforming to IEC 68-2-7
Vibration resistance	Permissible acceleration		6gn, conforming to IEC 68-2-6
Dielectric strength at 50 Hz	Conforming to IEC 255-5	kV	6
Impulse withstand voltage	Conforming to IEC 801-5	kV	6

### Electrical Characteristics of Power Circuit

TYPE	TR2-D	UNIT	09301-12316	18321	25322-65361	80363-95365
Tripping class			10	10	10	10
Rated insulation Voltage (Ui)	Conforming to IEC 60947-4-1	V	<b>TR2-D09301~D32355:690V</b>		<b>TR2D40355~D95365:1000V</b>	
Rated operating voltage upto	Conforming to UL, CSA	V	600	600	600	600
Rated impulse withstand voltage (Uimp)		kV	6	6	6	6
Frequency limits	Of the operational current	Hz	0... 400	0...400	0...400	0...400
Setting range	Depending on model	A	0.1...13	16...18	17...70	63...193
Connecting to screw clamp terminal			Minimum / Maximum CSA			
Flexible cable without cable end	1 conductor	mm <sup>2</sup>	1.5 / 10	1.5 / 10	4 / 35	4 / 50
Flexible cable with cable end	1 conductor	mm <sup>2</sup>	1 / 4	1 / 6	4 / 35	4 / 50
Solid cable without cable end	1 conductor	mm <sup>2</sup>	1 / 6	1.5 / 4	4 / 35	4 / 50
Tightening torque		Nm	1.7	2.5	9	9
Connection to spring terminals			Minimum / Maximum CSA			
Flexible cable without cable end	1 conductor	mm <sup>2</sup>	1.5 / 4	1.5 / 4	-	-
SolidCable without cable end	1 conductor	mm <sup>2</sup>	1.5 / 4	1.5 / 4	-	-

### Operating Characteristics

TYPE	TR2-D	UNIT	09301-12316	18321	25322-65361	80363-95365
Temperature Compensation		°C	-20...+60	-30...+60	-30...+60	-20...+60
Tripping Threshold	Conforming to IEC 6047-4-1	A		1.14 + 0.06In		
Sensitivity to phase failure	Conforming to IEC 60947-4-1		Tripping current 25% above In			

### Auxiliary Contact Characteristics

Conventional thermal Curent		A	5					
Maximum consumption of operating coil of controlled contactors (Occasional operating cycles of contact 95 - 96)	AC Supply	V	24	48	110	220	380	600
		VA	100	200	400	600	600	600
		V	24	48	110	220	440	-
		W	100	100	50	45	25	-
Short circuit protection	By gG or BS fuse Max. rating or by GB2 circuit-breaker	A	5					
Connection to screw clamp terminal			Minimum / Maximum CSA					
Flexible cable without cable end	1 or 2 conductors	mm <sup>2</sup>	1 / 2.5					
Flexible cable withcable end	1 or 2 conductors	mm <sup>2</sup>	1 / 2.5					
Solid cable without cable end	1 or 2 conductors	mm <sup>2</sup>	1 / 2.5					
Tightening torque	1 or 2 conductors	Nm	1.85					
Connecting to spring terminal			Minimum / Maximum CSA					
Flexible cable without cable end	1 or 2 conductors	mm <sup>2</sup>	1 / 2.5					
Solid cable without cable end	1 or 2 conductors	mm <sup>2</sup>	1 / 2.5					

## Overload Relays - Specifications

### Overload Relay (Class 10), Base Plate for Independent Mounting

RELAY REFERENCE	RELAY SETTING RANGE (A)	STANDARD POWER RATINGS OF SPARE MOTORS 500Hz AC3 CATEGORY					BACK UP		BASE PLATE* REFERENCE
		220V KW	380V KW	415V KW	440V KW	660V KW	FUSE RATING aM(A)	g1 (A)	
TR2-D09301	0.1 to 0.16	-	-	-	-	-	0.25	2	TA7D0964
TR2-D09302	0.16 to 0.25	-	-	-	-	-	0.5	2	
TR2-D09303	0.25 to 0.4	-	-	-	-	-	1	2	
TR2-D09304	0.4 to 0.63	-	-	-	-	0.37	1	2	
TR2-D09305	0.63 to 1	-	-	-	-	0.55	2	4	
TR2-D09306	1 to 1.6	-	0.37	-	0.55	1.1	2	4	
TR2-D093X6	1.25 to 2	-	0.55	0.75	0.75	1.3	4	6	
TR2-D09307	1.6 to 2.5	0.37	0.75	1.1	1.1	1.5	4	6	
TR2-D09308	2.5 to 4	0.75	1.5	1.5	1.5	3	6	10	
TR2-D09310	4 to 6	1.1	2.2	2.2	2.2	4	8	16	
TR2-D09312	5.5 to 8	1.5	3	3.7	3.7	5.5	12	20	
TR2-D09314	7 to 10	2.2	4	4	4	7.5	12	20	
TR2-D12316	9 to 13	3	5.5	5.5	5.5	10	16	25	
TR2-D18321	12 to 18	4	7.5	9	9	15	20	35	
TR2-D25322	17 to 25	5.5	11	11	11	18.5	25	50	
TR2-D32353	23 to 32	7.5	15	15	15	-	40	63	
TR2-D32355	28 to 36	9	15	18.5	18.5	-	40	80	
TR2-D40355	30 to 40	10	18.5	22	22	30	40	100	
TR2-D65357	37 to 50	11	22	25	25	37	63	100	
TR2-D65359	48 to 65	18.5	25	30	30	50	63	100	
TR2-D65361	55 to 70	20	30	37	37	55	80	125	
TR2-D80363	63 to 80	22	33	40	40	59	80	125	
TR2-D95365	80 to 93	25	45	49	50	80	100	160	
LR1-F105	65 to 105	25	51	55	59	90	0.25	160	
LR1-F125	80 to 125	30	59	59	63	110	125	200	
LR1-F160	100 to 160	45	80	80	90	140	160	250	
LR1-F200	125 to 200	55	90	100	110	160	200	315	
LR1-F250	160 to 250	63	110	129	140	200	250	400	
LR1-F315	200 to 315	80	150	160	160	257	315	500	
LR1-F400	250 to 400	110	185	200	220	335	400	630	
LR1-F500	315 to 500	140	250	257	280	445	500	800	
LR1-F630	400 to 630	180	315	355	375	500	630	800	
*LR1-F800	500 to 800	220	400	425	450	—	-	1000	
*LR1-F1000	630 to 1000	295	500	500	500	—	-	1250	



TR2-D25322



LR1-F105

Notes : 1. Protected shrouds for main poles or power poles to be ordered separately for LR1 Relays

2. Standard Fault Ratings   with TR2 Relay.

\*Under UL/CSA approval

### Reset Extended Push Button

Description	Reference
Reset Extended Push Button (Round Type)	RCB2AL8R
Reset Extended Push Button (Hex Type)	RCB2AL8H

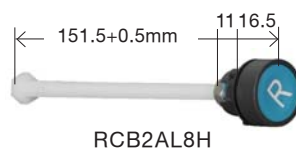
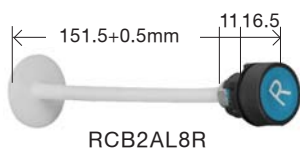

## Overload Relays Dimensions, Tripping Curves

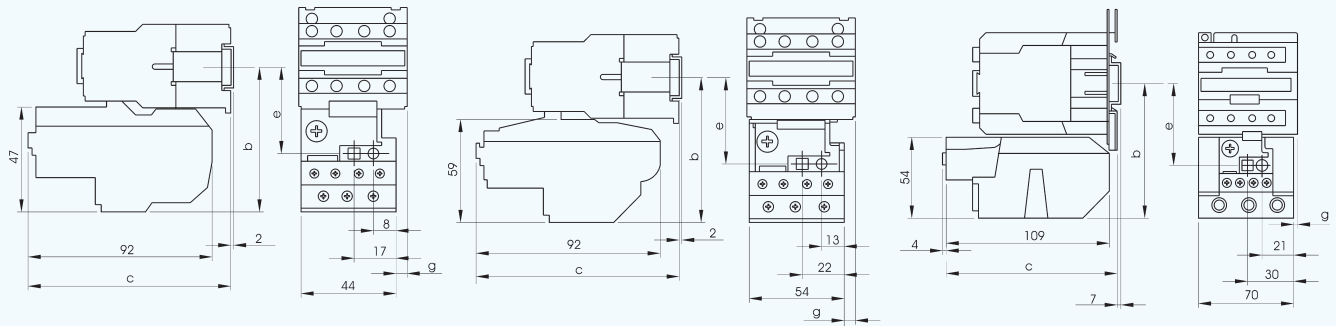

TR2D09301 - D25322				
Mounting With	b	c	e	g
TC1D09, D12, D18	81	98	50	0
TP1DC09, DC12				
TC1D25 / TP1DC25	86	108	55	10.7
TC1D32	86	109	55	8.1
TP1D09, D12, D18	81	133	50	0
TP1D25	86	152	55	10.7
TP1D32	86	153	55	8.1

TR2D32353 - 32355				
Mounting With	b	c	e	g
TC1D25/TP1DC25	97.5	98	60	1.5
TC1D32	97.5	98	60	0.5
TP1D25	97.5	155	60	1.5
TP1D32	97.5	155	60	0.5

TR2D40355 - D95365				
Mounting With	b	c	e	g
TC1D40	111	119	72.4	4.5
TC1D50	111	119	72.4	4.5
TC1D65	111	119	72.4	4.5
TC1D80	115.5	123.4	76.9	9.5
TC1D95	115.5	123.4	76.9	9.5
TP1D40	111	176	72.4	4.5
TP1D50	111	176	72.4	4.5
TP1D65	111	176	72.4	4.5
TP1D80	115.5	179.4	76.9	9.5

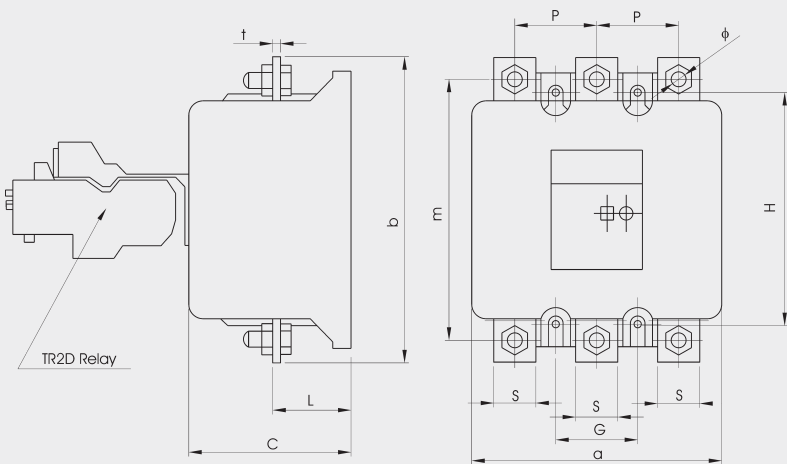

LR1 - F	a	b	C	G	H	L	M	P	S	φ	t
<b>105</b>	126	160	81	40	110	56	140	40	20	9	3
<b>125</b>	126	160	81	40	110	56	140	40	20	9	3
<b>160</b>	126	160	81	40	110	56	140	140	20	9	3
<b>200</b>	126	160	81	40	110	56	140	140	20	9	3
<b>250</b>	171	182	120	49	140	44.5	157	48	25	11	4
<b>315</b>	171	182	120	49	140	44.5	157	48	25	11	4
<b>400</b>	171	182	120	49	140	44.5	157	48	25	11	4
<b>500</b>	171	194	120	49	140	45.5	164	55	25	11	5
<b>630</b>	171	194	120	49	140	45.5	164	55	30	11	5

